

EQUATORE

Gabriele e Oscar Buratti, 2017

Equatore is a contemporary reinterpretation of the classic lamp with a glass shade. While the traditional abat-jour uses the shade to contain the light source within, in this family of lamps the shade is paradoxically and suggestively empty, with the light being generated by two luminous discs placed inside a central metal band, visible on the shade, that evokes the line of the equator. The light produced by the Leds, thanks to internal screens arranged in layers, is distributed regularly across the surface of the discs, magically illuminating them. The lower disk directs the light output downward, the upper one illuminates the glass cap for a soft, diffused light. Available in table, floor and ceiling models, in two sizes and two colors: a cooler version in gray with a dark chrome frame, and a warmer version with a transparent dove gray cap and a copper-colored frame.



RELATED PRODUCTS



EQUATORE

Floor Lamp



EQUATORE

Suspension Lamp

TECHNICAL SHEET

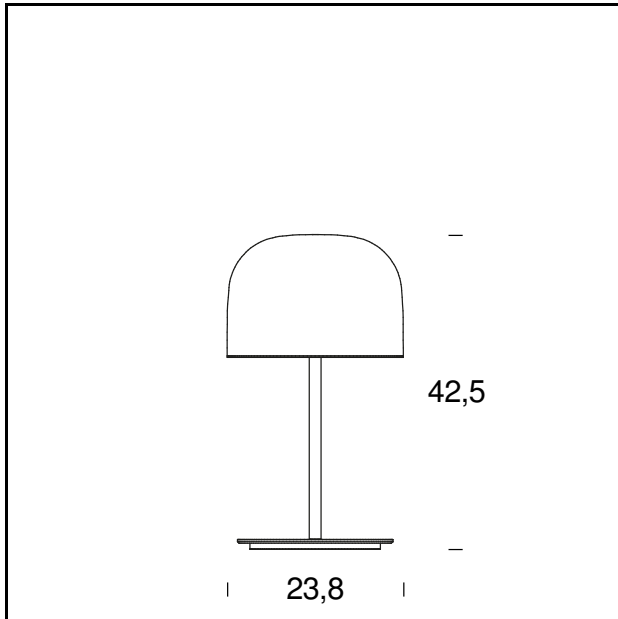

MODEL NAME: Equatore

CODE: 4389/0..

DIMENSIONS: Ø 23,8 x 42,5

MATERIALS: Glass, metal

COLORS

 Chrome/Grey

 Copper/Pink

BULB: 12W Led (2700K, CRI>90, Lumen 1100)

DIMMER: Dimmer

CERTIFICATIONS AND SYMBOLS:

 IP20  Classe III

TECHNICAL SHEET

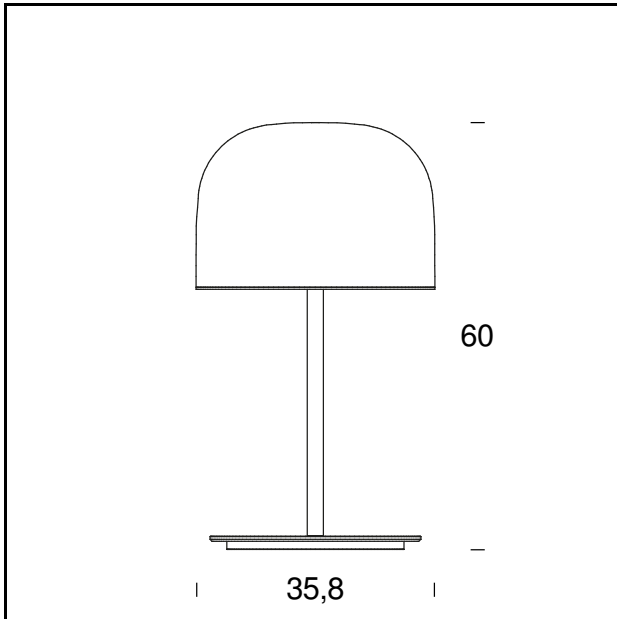

MODEL NAME: Equatore

CODE: 4389..

DIMENSIONS: Ø 35,8 x 60

MATERIALS: Glass, metal

COLORS

 Chrome/Grey

 Copper/Pink

BULB: 20W Led (2700K, CRI>90, Lumen 1800)

DIMMER: Dimmer

CERTIFICATIONS AND SYMBOLS:

 IP20  Classe III

Subject to technical modifications and modifications to content